

**THIRD SEMESTER DIPLOMA EXAMINATION IN ELECTRICAL
AND ELECTRONICS ENGINEERING — APRIL, 2017****MECHANICAL ENGINEERING**

[Time : 3 hours]

(Maximum marks : 100)

PART — A

(Maximum marks : 10)

Marks

I Answer the following questions in one or two sentences. Each question carries 2 marks.

1. Define manometers. How they are classified ?
2. State the limitations of Bernoulli's theorem.
3. State the causes of water hammer in pipes.
4. Define IC engine.
5. Define air lift pump.

(5×2 = 10)

PART — B

(Maximum marks : 30)

II Answer *any five* questions from the following. Each question carries 6 marks.

1. Explain the atmospheric pressure, gauge pressure and vacuum pressure.
2. The vacuum gauge reads 600mm of Hg vacuum. Find the absolute pressure in bar. Assuming the atmospheric pressure is 1.01 bar.
3. Explain in brief three different types of energies contributing to total hydraulic energy.
4. Define the terms laminar flow and turbulent flow.
5. Explain with sketch working of a simple boiler.
6. Differentiate between impulse turbine and reaction turbine.
7. Compare centrifugal pump and reciprocating pump.

(5×6 = 30)

PART — C

(Maximum marks : 60)

(Answer *one* full question from each unit. Each full question carries 15 marks.)

UNIT — I

- III (a) Explain how pressure can be measured using Piezometer. 7
- (b) A differential U-tube manometer containing mercury was used to measure difference in two pipes containing different liquids, as shown in figure. Find out the pressure difference in terms of KPa.

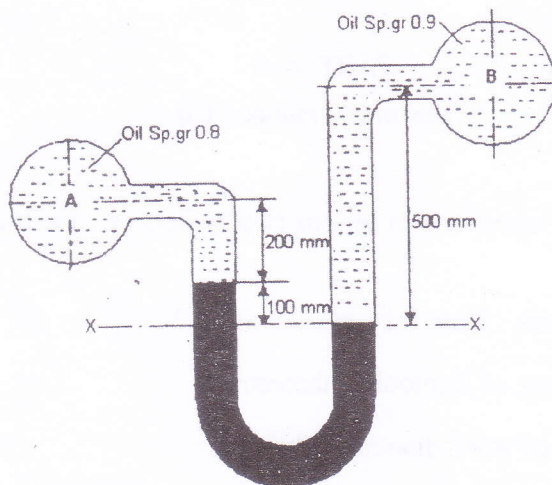

8

OR

- IV (a) Compare :
- (i) Uniform flow and Non uniform (ii) Steady flow and unsteady flow 7
- (b) An inverted U-tube manometer is connected with two pipes M & N which carries an oil of specific gravity 1.2 and 0.8 respectively. The fluid in the manometer is a light liquid of specific gravity 0.7. For the manometer readings are shown in the figure. Find the pressure difference between M and N.

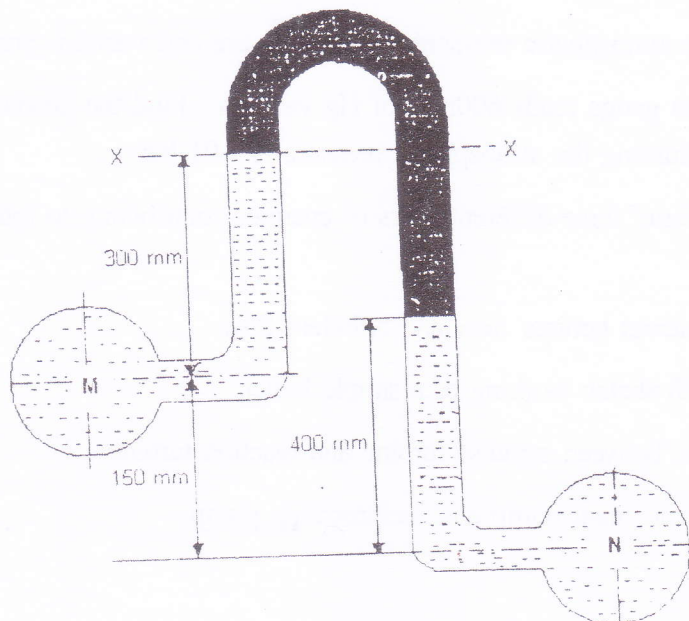

8

UNIT — II

- V (a) Write the Darcy - Wesbach's and Chezy's formula and explain the terms. 7
- (b) A horizontal Venturimeter whose inlet and throat diameters are 300 mm and 150 mm respectively is used to gauge the flow of water. The differential gauge connected to the inlet and throat shows a reading of 185 mm of mercury. Find rate of flow. Take $C_d = 0.975$. 8

OR

- VI (a) Define the loss of head in pipes. List out major and minor losses in pipes. 7
- (b) Water flows through a pipe 200 mm diameter 60m long with a velocity of 2.5 m/s. Find the head lost in friction.
- (i) By using Darcy's formula, if $f = 0.005$
- (ii) By using Chezy's formula, when $C = 55$ 8

UNIT — III

- VII (a) Differentiate fire tube and water tube boilers. 7
- (b) Explain the working of four stroke diesel engine. 8

OR

- VIII (a) Differentiate between petrol engine and diesel engine. 7
- (b) Explain working of two stroke petrol engine. 8

UNIT — IV

- IX (a) Explain the working of Francis turbine. 7
- (b) Explain the working of centrifugal pump. 8

OR

- X (a) Explain the working of Kaplan turbine. 7
- (b) Describe working of reciprocating pump. 8